

9TH
ED.



21 - 22
DEC
2024

9TH EDITION, 21-22 DECEMBER 2024

The 9th edition of GIVE PRINT A CHANCE takes place on SATURDAY 21st & SUNDAY 22nd DECEMBER from 10h to 20h at [Print Workers Barcelona](#) and with FREE ENTRANCE.



[Give Print a Chance](#) is a great small-format marketplace. Thus, in 2023, the total flow of attendees was aprox. 1.100 people. And in the penultimate edition (2022). After 2 years of pandemic absence, approximately 800 people.

And as usually happens in all markets among the 25 participating artists some sold a lot and others less.

We recommend that artists value above all the experience of participating in this event for lovers of screenprinting in Barcelona.

..... ↙
: **By participating in the Give Print a Chance you agree to all the** :
: **terms & conditions of this Open Call.** :
:
:



ALLOCATION OF TABLES:

The spaces available for artists are distributed in three Print Workers Barcelona spaces: Coworking, Studio and Living Room. Being the Coworking the area that usually accumulates more public in addition to the Shop where the Print Workers catalog is for sale.



Places will be allocated on a *first come, first served* basis: as applications are received and artists are selected, places will be allocated in the Coworking space. Once this space is full, it will be extended to the Studio and Living Room if necessary. Thus completing a maximum selection of approx. 25 local and *long distance* (from outside Barcelona) artists.

WE OFFER YOU:

- Table + exhibition space: wall or hanging panel (see Pages 4, 5, 8 y 10).
- Free accommodation for *long distance* artists & discount for accompanying people (Page 11).
- 2 chairs + 1 / 2 lamps + 2 plugs + wastebasket.
- VISA POS exclusively for artists (Page 12).
- WIFI Fiber Optic.
- Poster 9th Edition Give Print a Chance (*handmade edition*) with the names of the artists.

- *Welcome Pack*: tote bag, notebook & official *sticker*.
- Mentions in all the promotion of the event.
- Give Print a Chance will have a budget of approx. 2.000€ exclusively for promotion:

- RRSS Print Workers Barcelona (Instagram 18.000, Facebook 17.000)
- Newsletter Print Workers Barcelona (5.000 subscribers)
- Advertising and presence in agendas: BTV Gràcia, BcnMes, TimeOut, Gato News, Independent de Gràcia, Què Fem...
- Posters and flyers distribution Give Print a Chance Market



1. COWORKING



Up to 11 tables and spaces availables

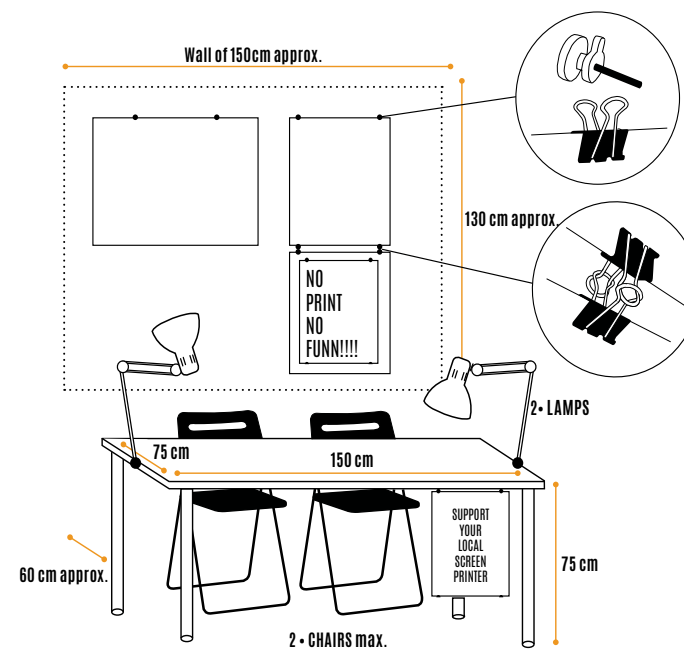

Plus alternative options: 4 tables of 120x60cm or 2 tables of 200x60cm arranged in the center of the Coworking with 2 double-sided hanging display panels of approx. 100x70cm. No back wall.



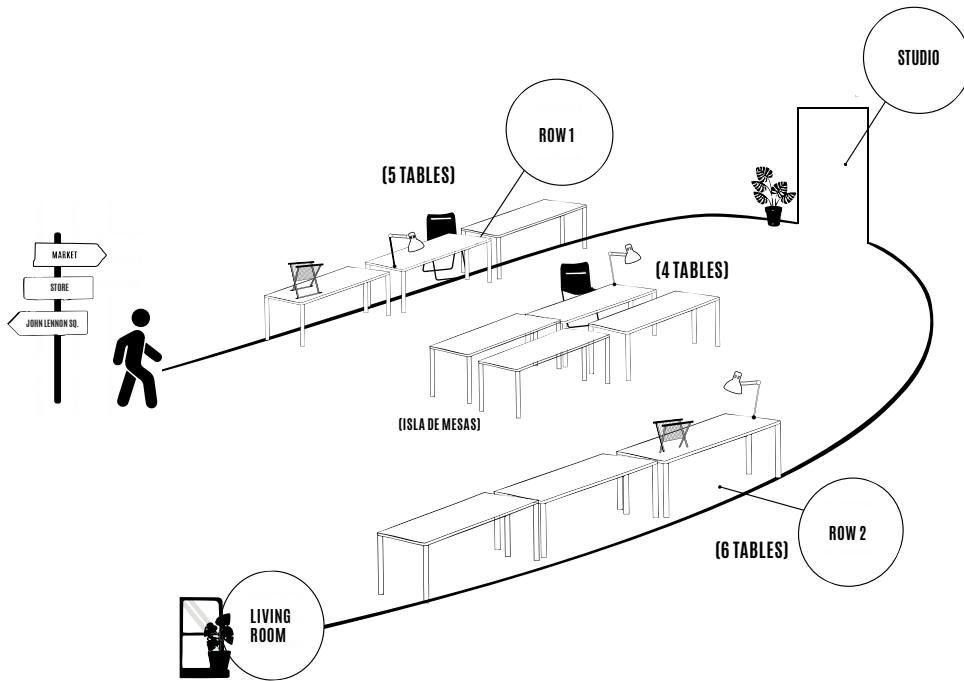

The space is U-shaped, each row with their respective exhibition wall. And an extra exhibition area in the form of an *island* with panels as well.

Pictures by [Antighost](#). Give Print a Chance 2023



2. STUDIO

In the unusual setting of our workshop we set up up to 6 tables and exhibition spaces. All the tables have the same measures but the exhibition spaces vary according to their distribution in space. Contact us for more details.



Pictures by [Antighost](#). Give Print a Chance 2023

On the upper mezzanine is the exhibition and permanent collection of *máculas* and test prints. Another incentive for the public to move from the Coworking area to the Studio.



Exhibition of *máculas* & test prints: This collection is located in the Studio's mezzanine. And all the pieces are for sale.



printworkersbarcelona.com

7

Up to 6 tables and spaces available of different sizes enabled in our Studio and workshop.

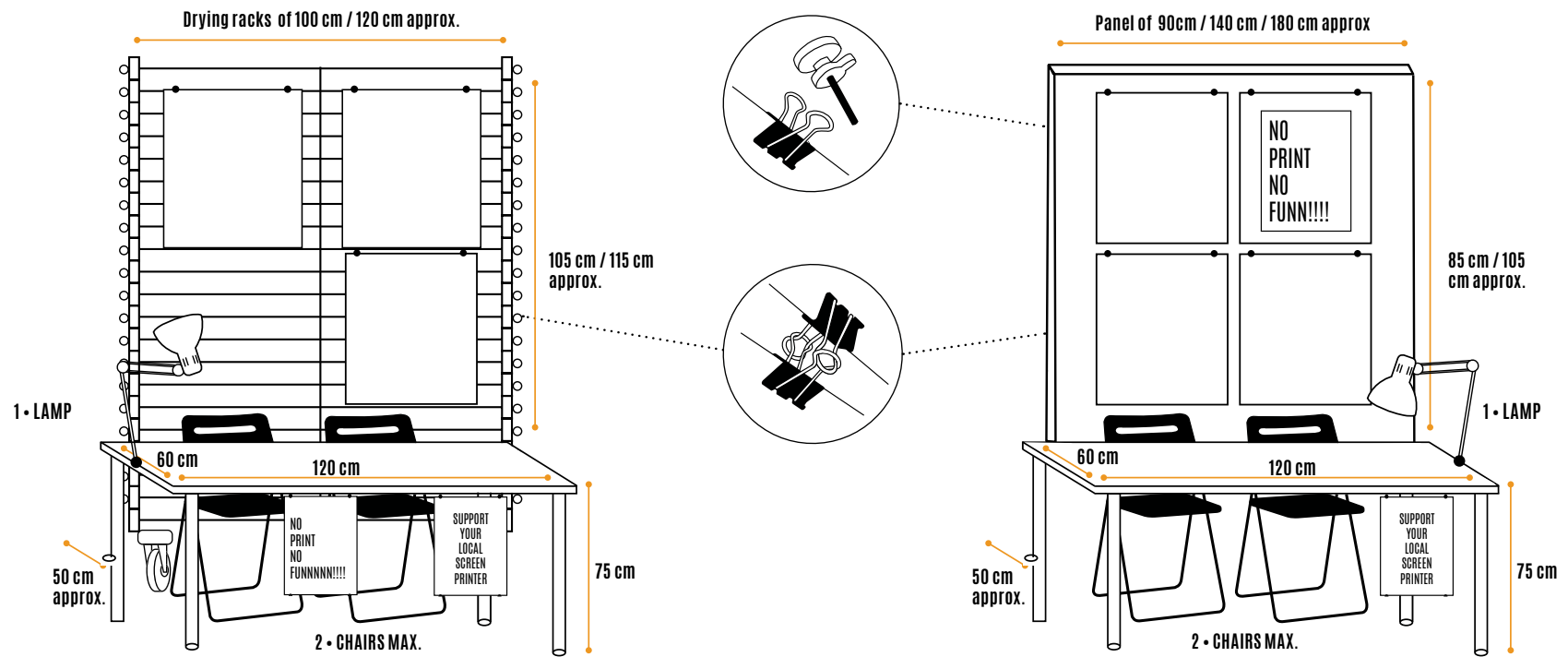

3. LIVING ROOM

We enable our Living Room as a sales space for a maximum of 2 artists. It is a very pleasant space that, by having less public flow, offers you more exhibition space.

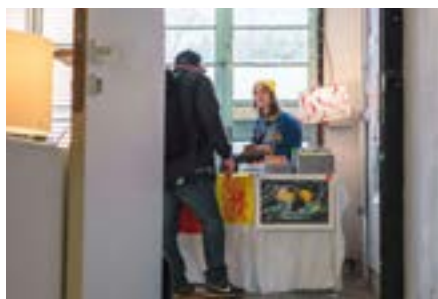

Photographs by [Antighost](#). Give Print a Chance 2023

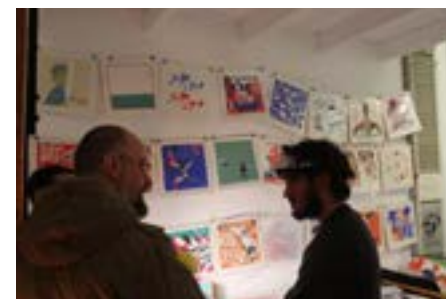

Up to 2 tables & two exhibition walls enabled in the Living Room.
(Wide angle graphic mode)

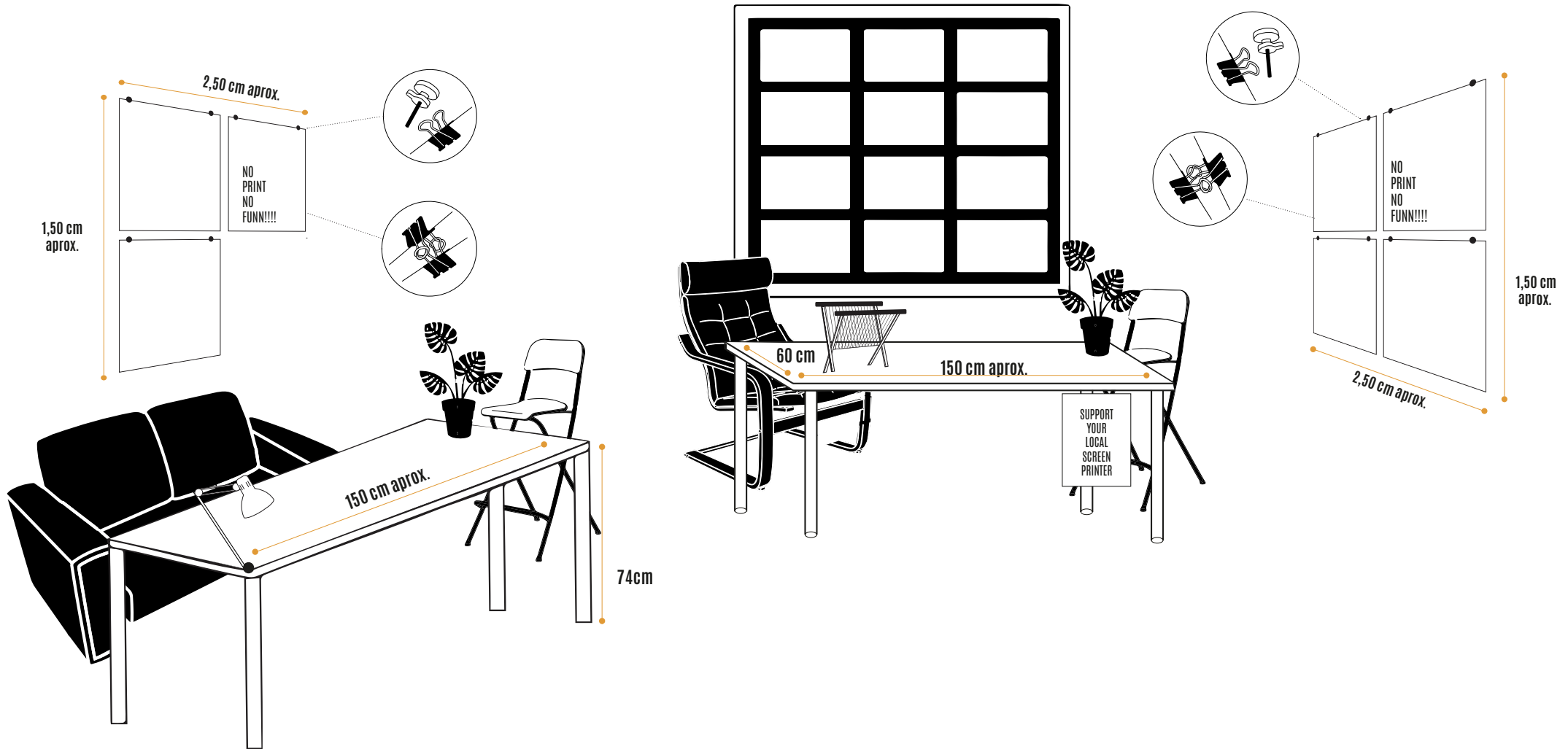

FREE ACCOMMODATION AT CASA JAM BARCELONA



Free accommodation in exchange for graphic work for Casa Jam

Thanks to the collaboration of Casa Jam Barcelona we offer FREE ACCOMMODATION to the *long distance* (from outside Barcelona) artists during the celebration of the Market.

Casa Jam is a *slow tourism* and eco sustainable hostel located just 5 minutes from Print Workers Barcelona.

www.casajambarcelona.com

If you are a *long distance* artist Casa Jam offers you free *shared rooms* from Friday night to Sunday night*.

We propose you a very simple exchange: **graphic work in exchange for accommodation**. Print Workers Barcelona, as *curators* for Casa Jam, will select during the Give Print a Chance a very small part of your work (according to the prices in your catalogue) for Casa Jam to decorate its space. In this way you will be able to stay for three nights* in their *shared rooms* without paying any money.

*Discounts of 20% for your companion and for the 4th night if your stay in Barcelona lasts more days.

*If you are interested in their double rooms, ask us about the available discount.



ASSEMBLY AND DISASSEMBLY

- The stand will be set up on SATURDAY 21st from 9h to 10h and dismantled on SUNDAY 22nd from 20h to 21h.
- Stands can be set up for both days without having to dismantle them at the end of Saturday.



WE RECOMMEND

- Please book as far in advance as possible.
- Facilitate cashless sales by having alternative card readers (eg. iZettle), Bizum or own POS (Credit Card Reader).



GENERAL INFORMATION

- Print Workers will also provide an exclusive VISA POS terminal for artists who will manage its use themselves.
- Sales of this POS will be reimbursed by Print Workers Barcelona:

In exchange for an official invoice from each artist.
Within a maximum period of one and a half months from receipt of the invoice.
Subtracting a 6% commission in favour of Print Workers.

- The work of the participating artists with a catalog in our shop will be removed from view. Except the one that's framed. This will avoid price or sales incompatibilities.
- The walls of the stands will be equipped with easy hangers / *cuelga fácil* to display the works. And the artists will provide the clamps to take down their prints from the easy hangers / *cuelga fácil*.



CONDITIONS TO PARTICIPATE

- Give Print a Chance is dedicated exclusively to **screenprinting**.
- The works for sale must be limited edition silkscreen prints, signed and numbered. And to a lesser extent risographs and letterpress.
- Artists who have abundant textile work such as t-shirts or tote bags will have to inform us in advance.
- The sale of digital prints, books or stories printed in offset or digital printing is not allowed. Nor ceramic or clay objects.



- The artists authorize the transfer of image rights (photos and/or videos) for promotional purposes of this event and future Print Workers Barcelona events. Being at your disposal the audiovisual material that is generated in the case that it is carried out by Print Workers Barcelona.
- By having the sponsorship of a local beer, it will not be allowed to bring alcohol from abroad.
- Prior authorization is required to promote events outside of Give Print a Chance.
- As far as possible, artists will communicate their participation on social media with the following hashtags: @printworkersbarcelona #giveprintachance #giveprintachance2024

Thank you very much for helping us with the promotion!



ASSEMBLY AND EXPOSURE CONDITIONS

- Respect assembly and dismantling times.
- Print Workers provides a clear cloth to cover the table up to the feet. The hidden interior of the table will serve as storage for suitcases, bags...
- Each artist will bring their own tweezers to assemble them with the easy hangers / *cuelga fácil* and the prints.
- Each artist is responsible for the cleanliness of their space. Removing at the end of the day the remains of food and garbage.

- No other wall and/or panel material such as nails or bluetack shall be used.
- It is recommended to bring thin ropes or fishing line in case they are necessary.
- In the case of tables with two light stands. One of them will always be kept focused on the ceiling to facilitate general lighting.
- The prices of the prints must always be clearly visible.



- It is not allowed to exhibit work beyond the space itself.
- Neither occupy common areas, corridors and stands of other artists.

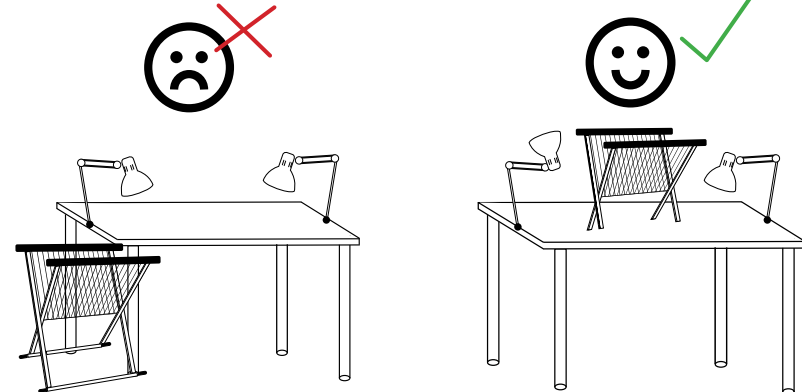

Thank you for keeping it that way!



SELECTION CRITERIA

For the selection of the participating artists, in addition to the quality of their work, we will value very positively...

- In the case of local artists, the production of their work in our [Studio](#). For trusting us and helping us keep the workshop active.
- In the case of *long distance* artists, the extra effort it takes for them to come to our annual event.
- The presence of artists with pieces in the catalogue of our [Shop](#). For keeping his work with us during these last two difficult years.
- And of course to all those artists who have been part of our [Academy](#) as teachers.



We will also prioritize...

- An abundant and constant production of limited edition pieces.
- Majority presence of pieces with a format greater than or equal to A3. We especially value pieces of 40x60cm, 50x70cm or even larger.
- Technical difficulty of the catalog of candidate artists.

And we will take into consideration...

- Competitive prices that reflect the effort of the artisanal edition and the value of the limited edition.
- Artists with very low sales prices that could harm the sale to other artists will not be selected.
- We will try that the editions in risography for their lower price are a minimum part of the catalog of the selected artists.



TIPS & RECOMMENDATIONS

How to make your plane ticket cheaper...

To reduce the cost of transportation, you can send us your prints in advance and by mail to Print Workers. Prepare a good package and send it to us 2 or 3 weeks in advance in case of any unforeseen events. We will keep it in our space. And when assembly day arrives you will find it on your table.

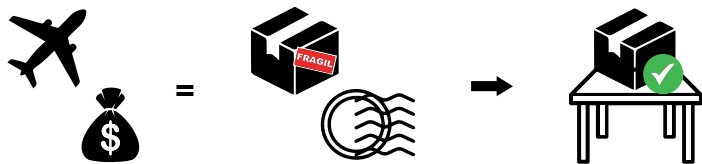

Rush Hour

We recommend spending as much time as possible at your table to increase sales possibilities. And for example, avoid taking a break during the hours when there are traditionally more people: from 12h to 13.30h approx. and from 17h to 18.30h approx. Although really the influx of public is simply unpredictable!



Finally...

We recommend wearing bright colors (like red) rather than more muted colors (like brown or gray) to attract attention. But of course there is no type of dress code and all looks are more than welcome.

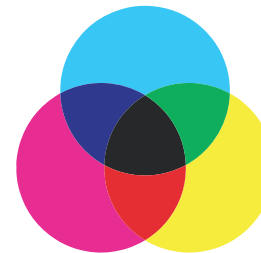

Also, since it is winter and all the doors are open, it is possible that the cold is felt a little. We offer you a blanket in case you need it.



REGISTRATION & FEES

- The Give Print a Chance registration fee reflects the selection criteria mentioned above.
- The deadline for registration is 31 October. We recommend booking as far in advance as possible.

ARTISTS	DISCOUNT	REGISTRATION with DISCOUNT
LOCALS with pieces printed in our STUDIO & with pieces in our SHOP catalogue	50%	99€ + IVA 21%
LONG DISTANCE with pieces in our SHOP catalogue	50%	99€ + VAT 0% / 99€ + IVA 21%
LOCALS with pieces in our SHOP catalogue	35%	129€+ IVA 21%
LONG DISTANCE without pieces in our SHOP catalogue	35%	129€ + VAT 0% / 129€ + IVA 21%
ART SCHOOLS & LOCALS without pieces in our SHOP catalogue	25% until October 15th	149€ + IVA 21%



METHOD OF PAYMENT

- **BANK TRANSFER**

IBAN ES75 0081 7012 4800 0160 7663

BIC/SWIFT: BSAB ESBB

Concept: GIVE PRINT A CHANCE and artists name.

Essential: Please send us the bank receipt to
hola@printworkersbarcelona.com

- **PAYPAL**

hola@printworkersbarcelona.com

Concept: GIVE PRINT A CHANCE and artists name.



CANCELLATION POLICY

- In case of cancellation of the Give Print a Chance due to major causes (pandemic or similar), a 25% discount will be offered for the next edition.
- If you are unable to attend once payment has been made, the registration fee will be forfeited and a 25% discount will be offered for the next edition.
- The registration fee will not be refunded under any circumstances.

..... ↙
• **BY PARTICIPATING IN THE GIVE PRINT A CHANCE YOU AGREE**
• **TO ALL THE TERMS AND CONDITIONS OF THIS DOCUMENT.**
.....

.....
• Give Print a Chance is a great small-format marketplace.
• In the last edition, the total flow of attendees was 1,100 people and
• in the penultimate edition, after 2 years of pandemic absence, ap-
• proximately 800 people.
• And among the 25 participating artists some sold a lot and others
• less.
• So we always try to make the artists value above all the experience
• of participating in this essential event for lovers of screenprinting in
• Barcelona.
.....



****THANK YOU FOR WANTING TO PARTICIPATE IN THE GIVE PRINT A CHANCE!****

And thanks to all the artists who have participated in previous editions of the **Give Print a Chance**:

LONG DISTANCE ARTISTS

ELISA TALENTINO (Turín), STUDIO TUTA (Turín), PIGMENT WORKROOM (Bari), MARTINA ZENA (Milán), JAN SEDMAK (Trieste), CLOCKWORK PICTURES (Roma), SUBSERI LA STAMPERIA SOTTERRANEA (Milán), ANNA FIETTA (Padova), PATRICK SABADDIN (Treviso), LARA OTTAVIANI (Bologna) ANTIGHOST (Manheim), ATELIER BURNS (Munich), MAKEARTE (Berlín), JELLE VAN GOSLIGA (Hamburgo), ZESAR (Stubben), MIRJAM DIJKEMA (Groningen), JORIS DICKS (Utrecht), (DE) CONCEPTUALISE (Rotterdam), STUDIO AMARGO (Rotterdam) JULIE LEGRAND (Sète), TAZAS (Toulouse), TOMELLO (Toulouse), VAVA DESIGN (Toulouse), SIR FAYE MUÑOZ (Burdeos), CHARLY ESCORSELL (Coufouleux), GUERRERO PROJECTS (París), DUGUDUS (París), POMP IT UP EDITIONS (Nancy), L'APPAT (Bruselas), ILEANA ROVETTA (Porto), CARAPAU AMARELO (Lisboa), BLANK! STUDIO GALLERY (Atenas), TIND (Atenas), REPLICA STUDIO (Tsalónica), SERIGRAFICA 7585 (London), LEO BOYD (Belfast), MANDY DOUBT (Norwich), TOBY RAMPTON (Norwich), SANNNI PYHÄNNISKA (Bristol), APRILLE ZAMMIT (Malta), SERIGRAPH (Kiev), OFYCINA PERYFERIE (Varsovia), KATYA POLEZHAEVA (Moscú), ILGIN NUCAR (Estambul), THE FINGERSMITH LETTERPRESS (Singapur), SOROCHE (Quito), RAT TRAP (Bogotá), VIVALAVIDATALLER (Buenos Aires), MARTIN LÓPEZ (Valencia), LA PLATANERA (Illa de Arousa), INDI & LALA (Madrid), MARCOS MORENO (Madrid), AMAZINK PRINT STUDIO (Madrid), LA CAVERNA (Madrid), LENGUA BASE (Madrid), ORA LABORA STUDIO (Segovia), CARLES G.O.D. (Mallorca), CHILDREN OF CORITA (Mallorca), HÉCTOR FRANCESC (Mallorca), PATO CONDE (Mallorca) y JESUS SAVES IBIZA (Ibiza).

LOCAL ARTISTS

CARMELA GÓMEZ, DIEGO MIRANDA (DIMM DESIGN), GEMMA QUEVEDO, BEA CRESPO, YANN KUTO, PINKPILL DESIGN, LA RODA TALLER, JAN BARCELÓ, MIGUEL BUSTOS, AGUSTÍ SOUSA, RAMÓN PARIS, EI MARQUÉS, MAR ESTRAMA, CLARA MUR, ADOLF RODRIGUEZ, EROLA BOIX, COLECTIVO BARICELA, CORNELIA KRAFT, CLARE NELSON, TXAN GRAU, OLGUJUSTI BASTARD, LA FAVORITA, BADABUM, ERLING KNUDSEN, ARAIZ MESANZA, JORDI SALVANY, NOUNUA, DO THE PRINT, JOAN ALTURO / BEC NEGRE, FABRIZIO CONTARINO, BUNKERTYPE, LAUREN PRESS, LA TRASTERÍA, LUCIA SEGURAMENTE, SERIGRAFIA MONOESTEREO, EL PUTO KEN, ZELLERLUOID, YOU ARE SO OVERRATED, NATALIA LISINICCHIA, EMILIANA LARRAGUIBEL, BARBA, EL DELETRISTA, DAMIÁN QUIROGA, LUCÍA CORTÉS, LANDER ARTWORK, KYLE BRYANT, HOLA EDICIONES, IRENE PEREZ, JULIO FUENTES, IRKUS, INDUSTRIAS DOC, CARMÉ PONS, LINO ALBO, ERROR! DESIGN. LUCAS AMARAL, BAD ASS PRINTS, ESPAI BRUT, ANA DELGAR, DO IT FUNK, EDICIONES RARITAS y WRONG CULTURE.

